

SmartArena TERA Gen3r Duo



SPECIFICATIONS

Luminous flux	up to 104,000 Lm
Rated power Rated voltage	400-650 W AC 220-240 V / 50/60 Hz optionally: AC 400 V / 50/60 Hz
Overvoltage protection	6kV DM, 10kV CM
Light distribution interchangeable optical system	The following reflectors are available: R 10° R 15° R 25° R 35° R 45° R 60°
Color temperature	3000 / 4000 / 5700 / TW / RGB
Power factor	> 0.96
IP protection class	IP66
Dimensions	300 x 777 x 300 mm (width x height x depth – with bracket, without optics)
Weight	12 kg
Luminous flux maintenance	50,000 h L90, min. 120,000 h L80 (Ta = 15° C)
Flicker	< 1 % – even when dimmed
Camera suitability	HD UHD/4k, 8k, SSM (super slow motion), High Speed
Aw/m ²	0.17
Maximal ambient temperature	Ta: +25° C
Impact resistance	IK08
Certifications	ENEC Ball impact safety – optionally available depending on the optical system
CRI	70 / 80 / 90+

The specified values are maximum values, which may vary depending on the specific use case. The voltage range must be defined for the project before ordering. The SmartArena TERA Gen3r series is only intended for the illumination of indoor and outdoor sports venues.

UPGRADES

DLC-System (Direct-Light-Control)	System for limiting glare and brightening rooms using geometric cut-off technology
Switch Dimming	Up to 3 freely programmable dimming levels – Retro-Fit: completely without additional wiring
DMX/RDM Dimming	0-100%
DALI Dimming	DALI-2 / D4i



Preworks GmbH
Technologiepark 4/1
8510 Stainz / Austria

SmartArena – a brand of
Preworks GmbH

+43 3463 82317
info@smart-arena.com
smart-arena.com



SmartArena
TERA Gen3r
Duo 10°

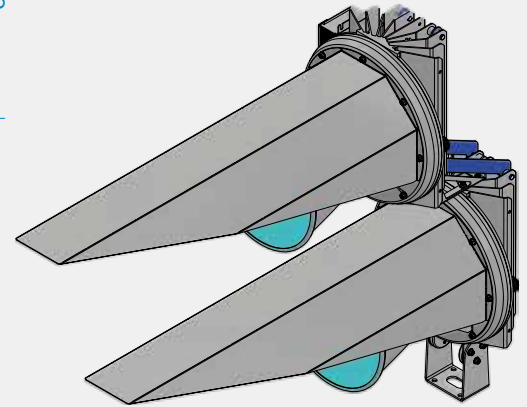
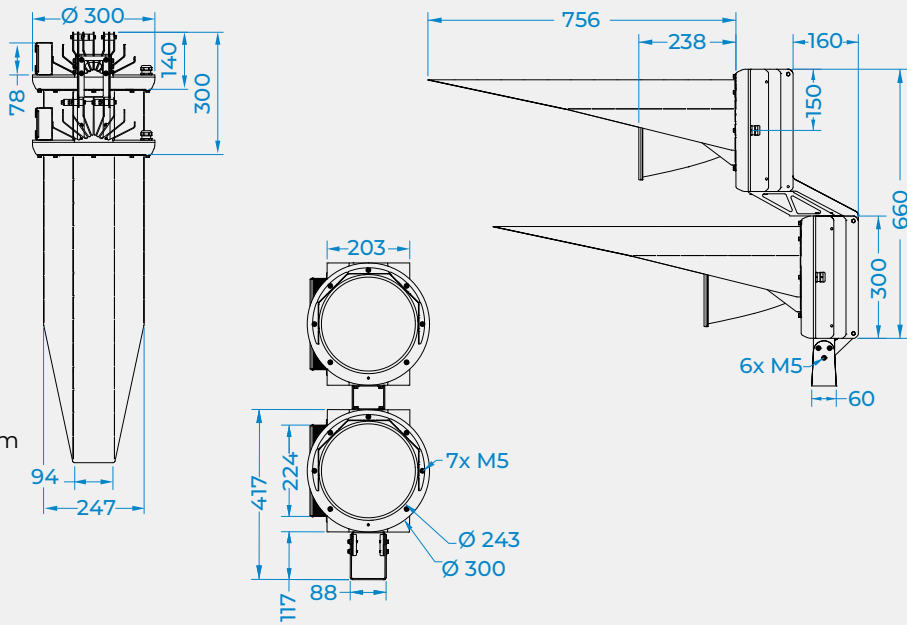

em ipsum

SmartArena
TERA Gen3r
Duo 15°-25°

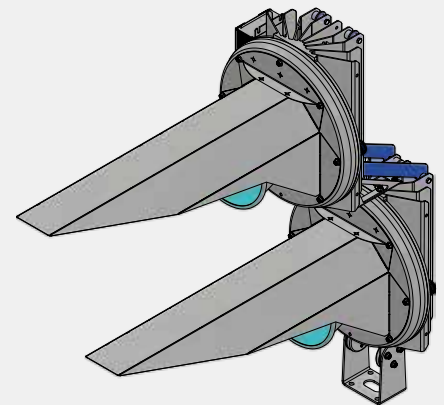
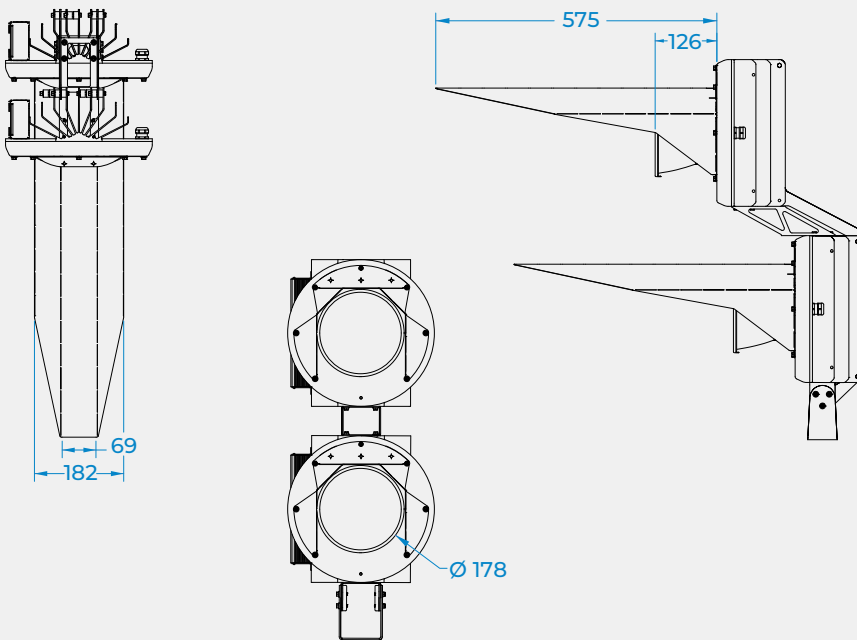

SmartArena
TERA Gen3r
Duo 35°-60°

