

SmartArena TERA Gen3r Quattro F



SPECIFICATIONS

| | |
|---|--|
| Luminous flux | up to 208,000 Lm |
| Rated power Rated voltage | 800-1500 W AC 220-240 V / 50/60 Hz optionally: AC 400 V / 50/60 Hz |
| Overvoltage protection | 6kV DM, 10kV CM |
| Light distribution interchangeable optical system | The following reflectors are available: R 10° R 15° R 25° R 35° R 45° R 60° |
| Color temperature | 3000 / 4000 / 5700 / TW / RGB |
| Power factor | > 0,98 |
| IP protection class | IP66 / IP67 |
| Dimensions | 602 x 777 x 286 mm (width x height x depth – with bracket, without optics) |
| Weight | 32 kg |
| Luminous flux maintenance | 50,000 h L90, min. 120,000 h L80 (Ta = 15° C) |
| Flicker | < 1 % – even when dimmed |
| Camera suitability | HD UHD/4k, 8k, SSM (super slow motion), High Speed |
| Aw/m ² | 0.34 |
| Maximal ambient temperature | Ta: +40° C |
| Impact resistance | IK08 |
| Ball throwing safety | Optionally available depending on the optical system |
| CRI | 70 / 80 / 90+ |

The specified values are maximum values, which may vary depending on the specific use case. The voltage range must be defined for the project before ordering. The SmartArena TERA Gen3r series is only intended for the illumination of indoor and outdoor sports venues.

UPGRADES

| | |
|-----------------------------------|--|
| DLC-System (Direct-Light-Control) | System for limiting glare and brightening rooms using geometric cut-off technology |
| Switch Dimming | Up to 3 freely programmable dimming levels – Retro-Fit: completely without additional wiring |
| DMX/RDM Dimming | 10-100% stepless |
| DALI Dimming | DALI-2 / D4i |

ADDITIONAL FEATURES

Each light point can be controlled individually.
The Quattro F can be fitted with different optics.



Preworks GmbH
Technologiepark 4/1
8510 Stainz / Austria

SmartArena – a brand of
Preworks GmbH

+43 3463 82317
info@smart-arena.com
smart-arena.com

SCAN QR CODE



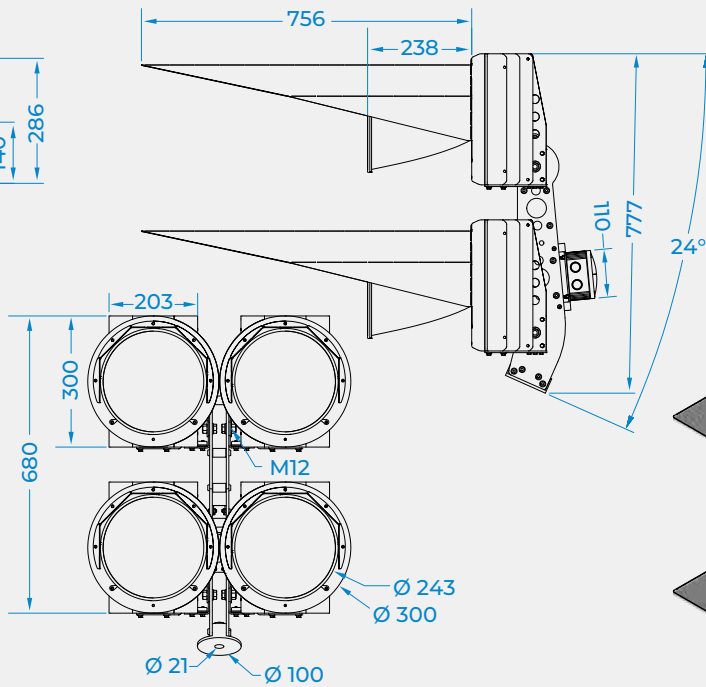
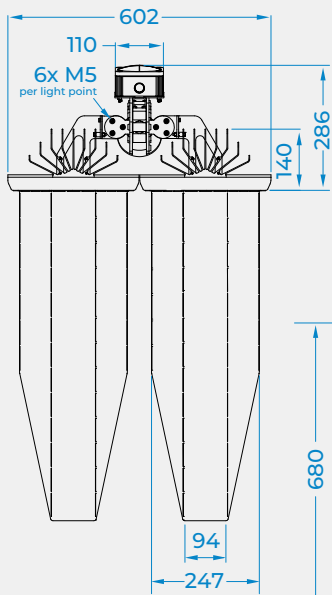

SmartArena
TERA Gen3r
Quattro F 10°

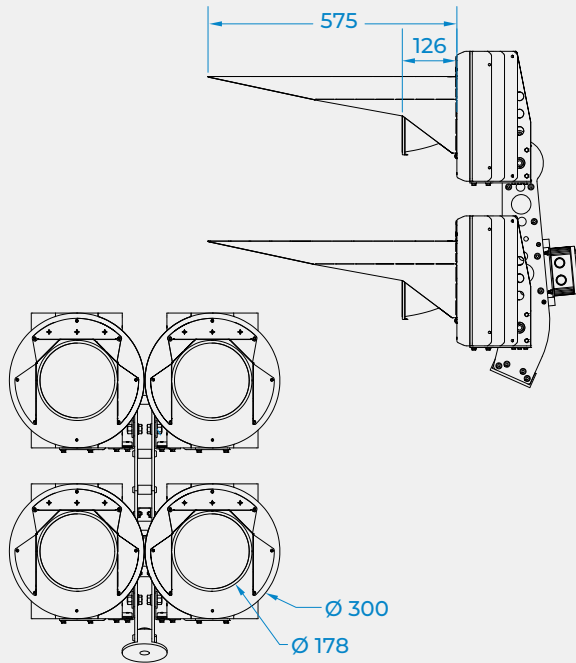
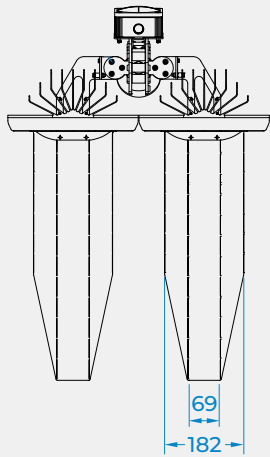
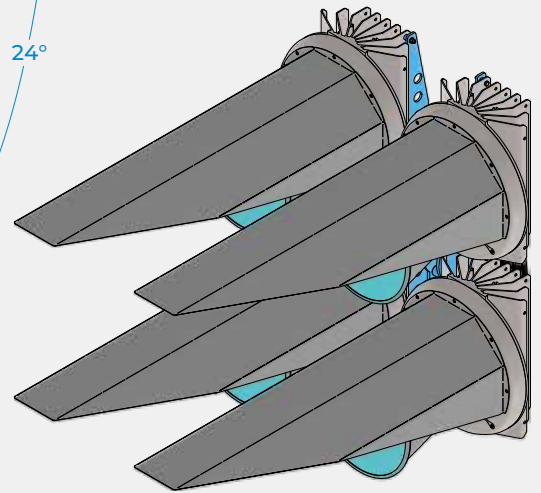

SmartArena
TERA Gen3r
Quattro F 15°-25°

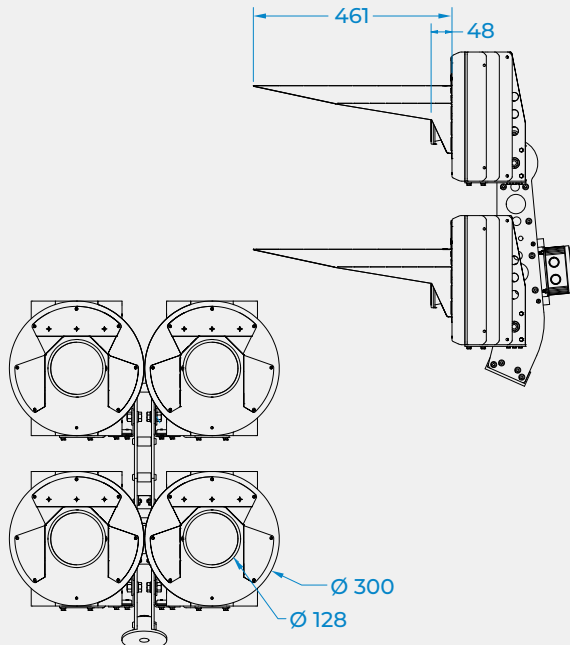
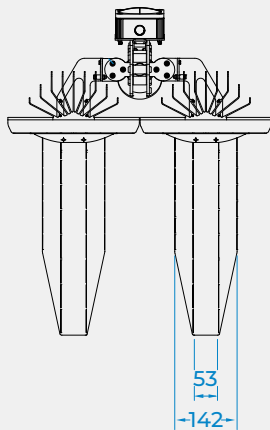
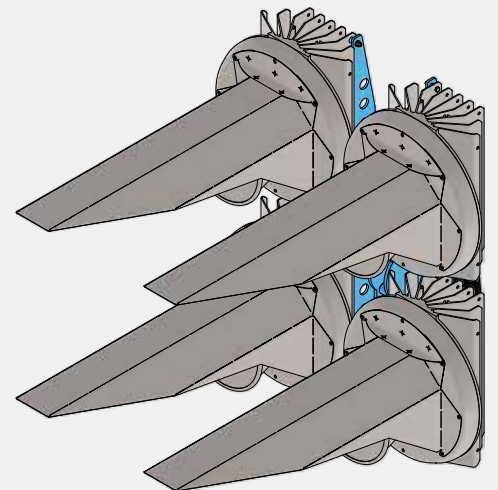

SmartArena
TERA Gen3r
Quattro F 35°-60°

